

MECHANICAL CASE OUTLINE
PACKAGE DIMENSIONS

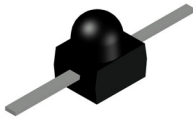

T-3/4 2.50x2.00
CASE 100CB
ISSUE A

DATE 14 SEP 2023

NOTES:

1. CONTROLLING DIMENSIONS: MILLIMETERS
2. DIMENSIONS DO NOT INCLUDE MOLD FLASH OR BURRS.
3. 2MM DETECTOR

| DIM | MILLIMETERS | | |
|-----|-------------|------|------|
| | MIN. | NOM. | MAX. |
| A | 2.50 | 2.70 | 2.90 |
| A2 | 1.30 | 1.40 | 1.50 |
| A3 | 1.30 | 1.40 | 1.50 |
| A4 | 0.60 REF | | |
| b | 0.45 | 0.55 | 0.65 |
| b1 | 0.35 | 0.45 | 0.55 |
| c | 0.10 | 0.15 | 0.25 |
| D | 2.30 | 2.50 | 2.70 |
| E | 1.80 | 2.00 | 2.20 |
| L | 7.00 | --- | --- |
| øD | 1.70 | 1.90 | 2.10 |

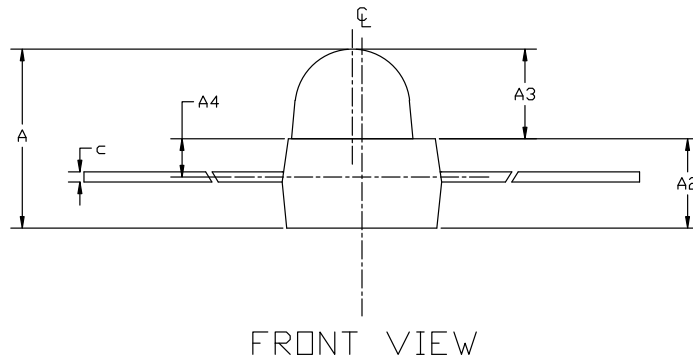
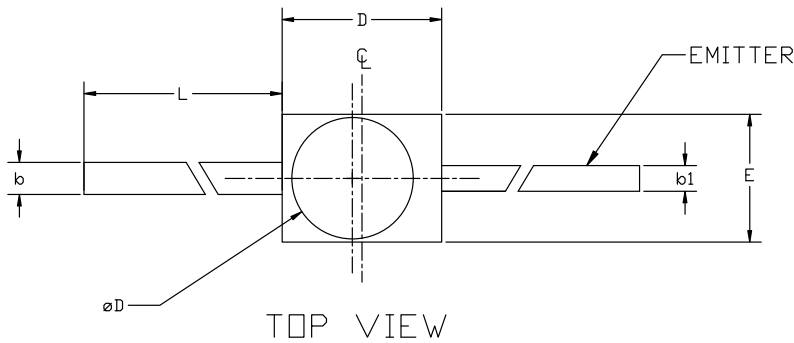

| | | |
|-------------------------|------------------------|---|
| DOCUMENT NUMBER: | 98AON13435G | Electronic versions are uncontrolled except when accessed directly from the Document Repository. Printed versions are uncontrolled except when stamped "CONTROLLED COPY" in red. |
| DESCRIPTION: | T-3/4 2.50x2.00 | PAGE 1 OF 1 |

onsemi and onsemi are trademarks of Semiconductor Components Industries, LLC dba onsemi or its subsidiaries in the United States and/or other countries. onsemi reserves the right to make changes without further notice to any products herein. onsemi makes no warranty, representation or guarantee regarding the suitability of its products for any particular purpose, nor does onsemi assume any liability arising out of the application or use of any product or circuit, and specifically disclaims any and all liability, including without limitation special, consequential or incidental damages. onsemi does not convey any license under its patent rights nor the rights of others.