

100 W TYPE-C PD3.0 / PPS Charger Solution Evaluation Board User's Manual

EVBUM2818/D

SPECIFICATION

onsemi's Device	Application	Input Voltage	Output Power	Topology	I/O Isolation
NCP1623ASNT1G NCP1343AMDCDBD1R2G NCP4307FASNT1G FUSB15101 FCMT250N65S3 FCMT199N60/FDMS86180 NTTFS4C02NTAG	Smart phone, PAD and NB adapter supporting PD3.0/PPS protocol	90 Vac to 264 Vac	100 W	VSFF PFC Flyback	Isolated (3 kV)

	PD Output Specification	PPS Output Specification
Output Voltage	5 V, 9 V, 12 V, 15 V, 20 V	3 V – 21 V
Nominal Current	5 V / 3 A, 9 V / 3 A, 12 V / 3 A, 15 V / 3 A, 20 V / 5 A	5 A
Max Current	5 V / 3 A, 9 V / 3 A, 12 V / 3 A, 15 V / 3 A, 20 V / 5 A	5 A

Avg. Efficiency	92.3% & 92.9% @ 20 V 3.25 A, 115 & 230 Vac
Ripple	<60 mV
Standby Power	<50 mW @ 5 V & 230 Vac (No cable plug in)
Power Density	1.46 W/cm ³
Protection	Adaptive UVP, OVP, SCP, OTP
PCBA Size	60 mm x 60 mm x 19 mm

CIRCUIT DESCRIPTION

This evaluation board user's manual describes a 100 W, Type C interface, universal AC input, constant voltage power supply intended for smart phone, PAD and NB adaptor supporting PD3.0/PPS protocol, where isolation from the AC mains is required, and low cost, high efficiency, and low standby power are essential.

The featured power supply is a simple QR flyback topology utilizing **onsemi's** NCP1623 VSFF PFC controller with 2 stage level, NCP1343 Multi-mode HF PWM controller with transient peak excursion power, NCP4307 synchronous rectified controller, **onsemi's** FCMT199N60/FCMT250N65/FDMS86180/NTTFS4C02 MOSFET. This evaluation board user's manual provides the complete circuit schematic details, PCB and BOM for 100 W Type C Interface PD3.0 Power adapter solution which supports PD output (5 V / 3 A, 9 V / 3 A, 12 V / 3 A, 15 V / 3 A, 20 V / 5 A).

This design combined with **onsemi's** FUSB15101 PD3.0/PPS protocol controller to provide PD3.0 and PPS

functions. This design also proposes a dual auxiliary power supply to supply PWM controller, the PWM controller is supplied by high voltage auxiliary voltage at low output voltage and supplied by low voltage auxiliary voltage at high output voltage.

NCP1623 is next generation of NCP1622 PFC controller and compatible with NCP1622, it provides two stage level output and greatly improves the efficiency at low line. NCP1343 has same die as NCP1342, blank IC can be trimmed for NCP1342 or NCP1343, so it should have same reliability as NCP1342. NCP1343 provides a PEM mode with CCM operation and allows to use smaller capacitance for bulk CAP and minimize transformer value for transformer, it will save more size and cost than NCP1342 in a PFC plus PWM applications.

This design also uses NCP4307 synchronous rectified controller which eliminated external Vcc circuit at low output, it is also configured on high side or low side.

EVBUM2818/D

KEY FEATURES & PERFORMANCES

- AC input from 90 V to 264 V
- VSFF CRM PFC with 2 stage output voltage, 250 V at LL and 390 V at HL
- HF CCM/CRM PWM with 2x PEM supports more power transition without PFC working and 68uF PFC capacitor
- High Frequency Operation up to avg. 190 kHz at 264 Vac & full load and easy to be changed to GaN solution
- Quite skip and Flyback DCM operation with frequency foldback at no load & light load
- Output voltage 3.3 V – 21 V
- Max Output power: 100 W
- Support PD3.0, PPS, BC1.2 etc.
- Ripple & Noise: <60 mV
- AVG efficiency: 92% at 115 Vac & 230 Vac
- Full load efficiency: 92.3% & 92.9% at 115 Vac & 230 Vac and 20 V 3.25 A
- Output precise OVP
- Output OCP, SCP
- Open loop protection
- Small size with compact design
- PCBA size: 60 mm x 60 mm x 19 mm

BOARD PHOTOS



Figure 1. Profile of 100 W TYPE-C PD Adapter Solution

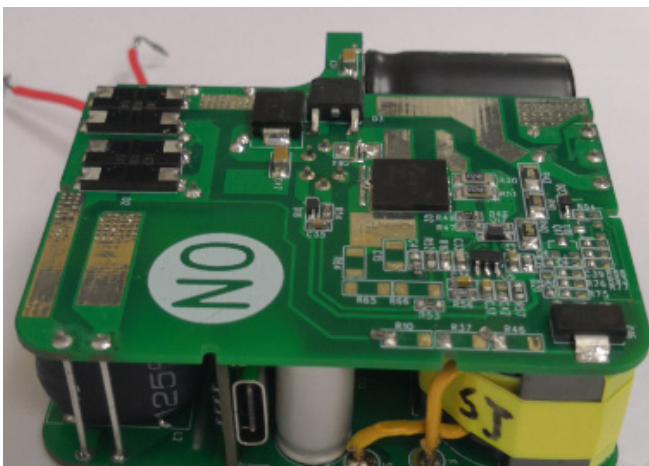

Figure 2. PFC Side View 1 of Demoboard

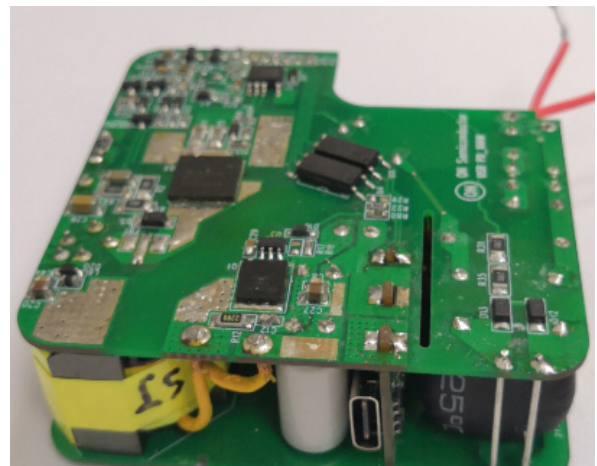

Figure 3. PWM Side View 1 of Demoboard

EVBUM2818/D

CIRCUIT SCHEMATIC (PFC)

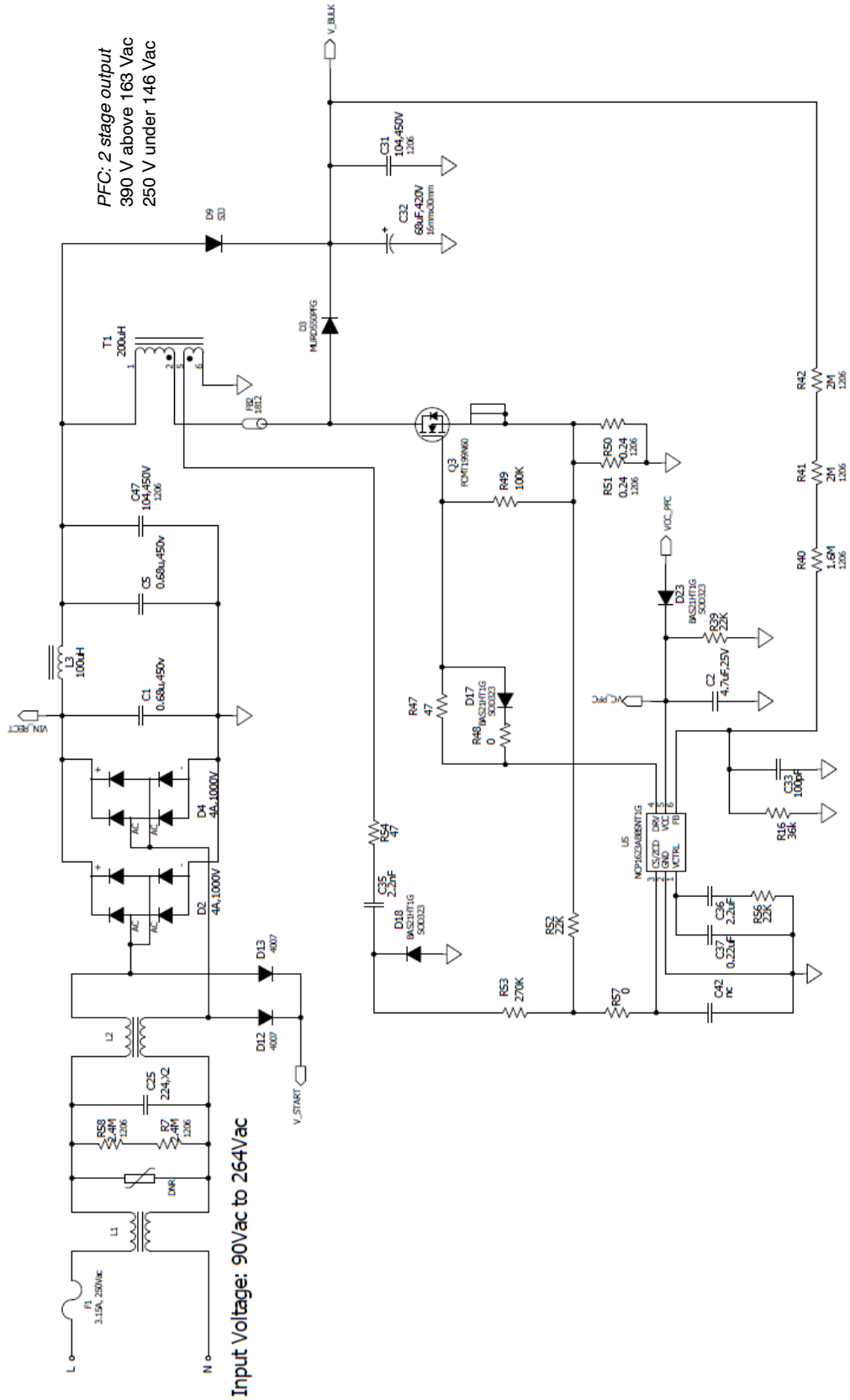

Figure 4. Circuit Schematic (PFC)

CIRCUIT SCHEMATIC (PWM & PROTOCOL)

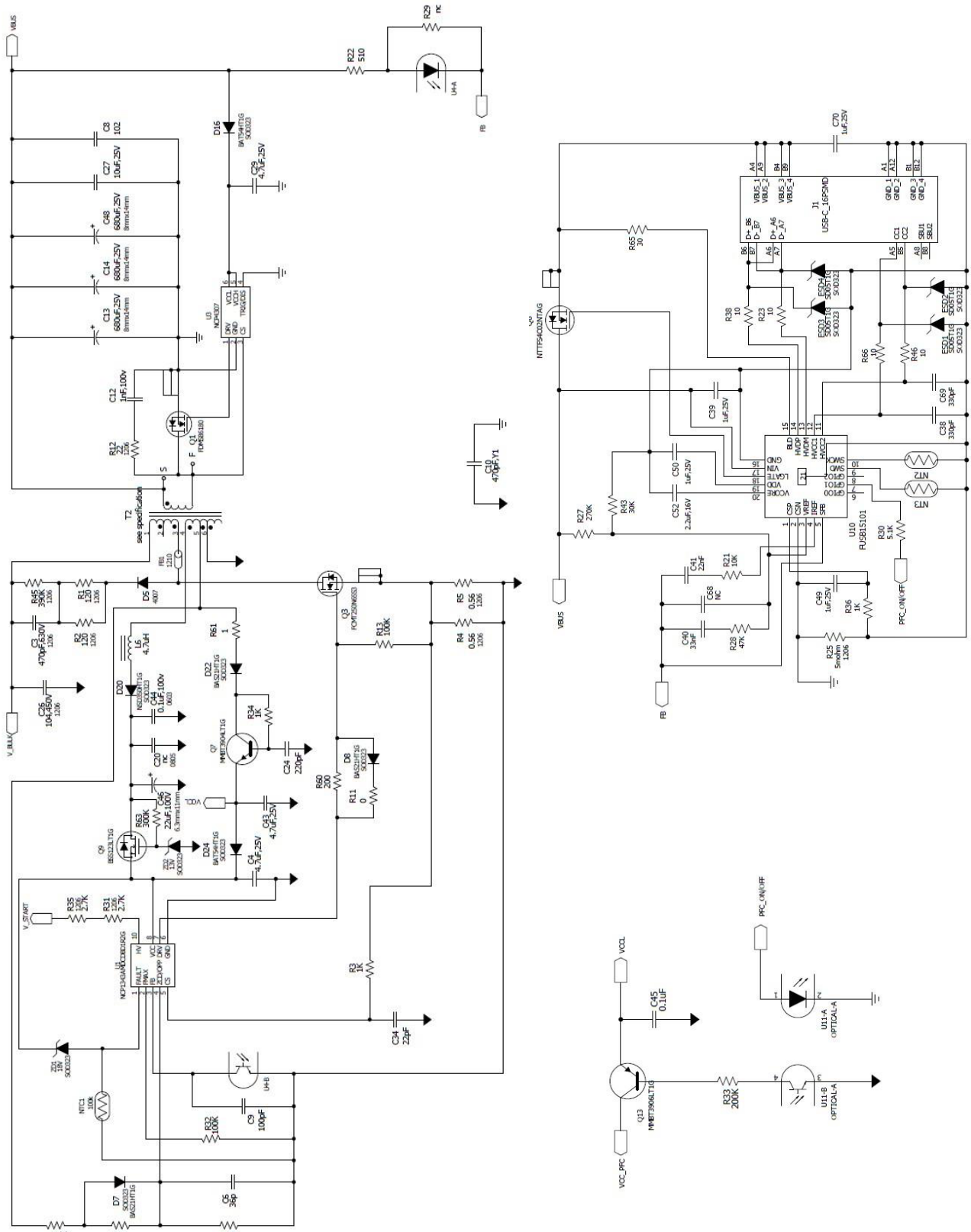

Figure 5. Circuit Schematic (PWM & Protocol)

PCB

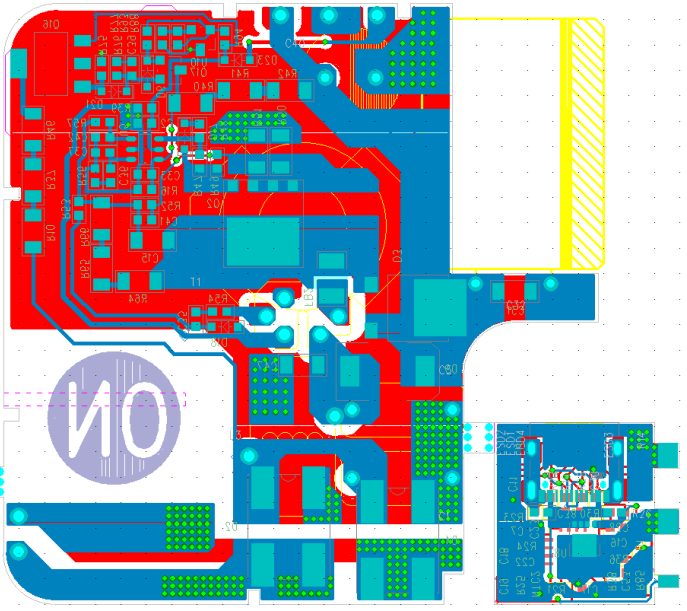
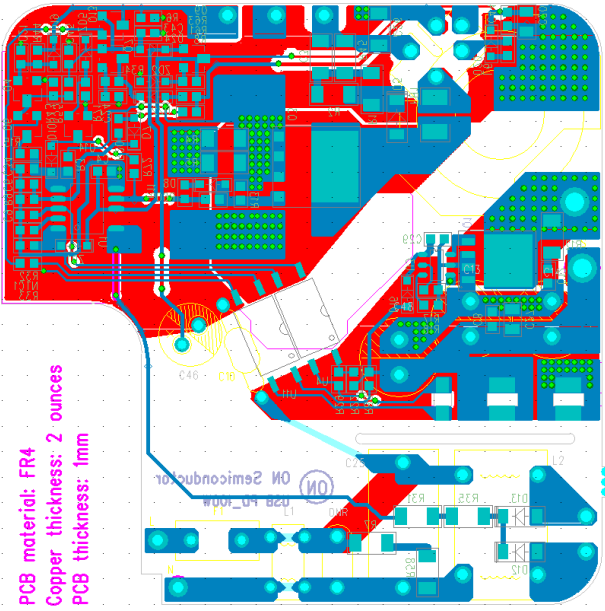
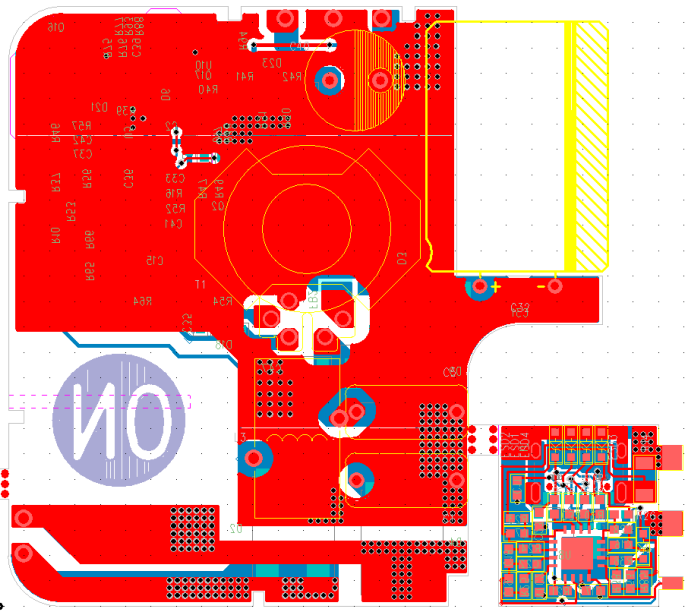
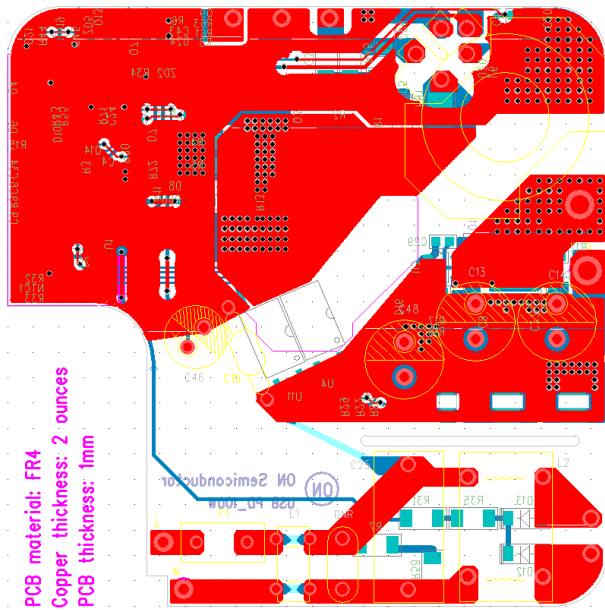

Figure 6. (Top), Top View of PCB

Figure 7. (Bottom), Bottom View of PCB

TRANSFORMER SPECIFICATION

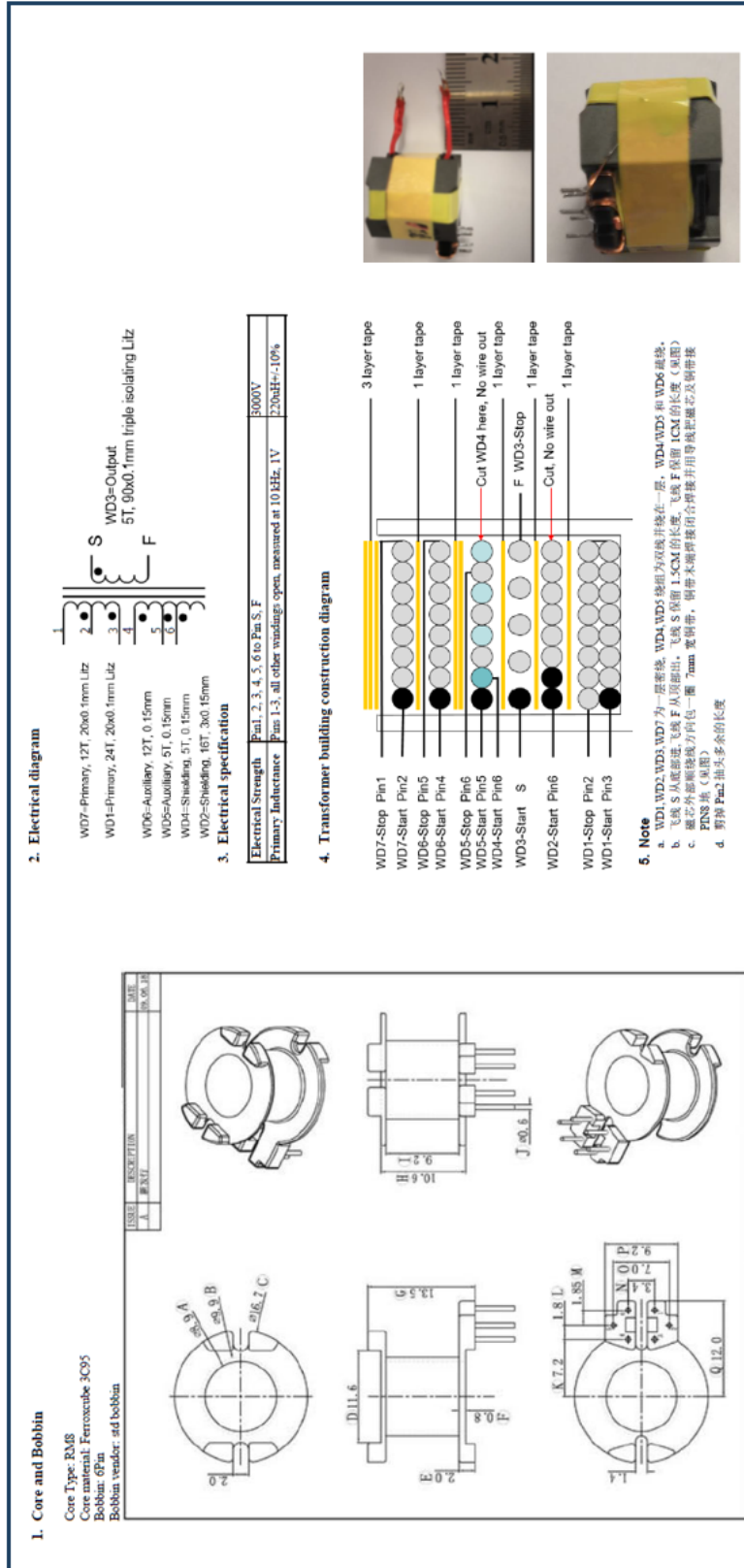

Figure 9. Transformer Specification

STANDBY POWER AT 5 V OUTPUT (CABLE UNPLUG) @ 90 Vac TO 264 Vac INPUT

(Test condition: all efficiency is tested at board end)

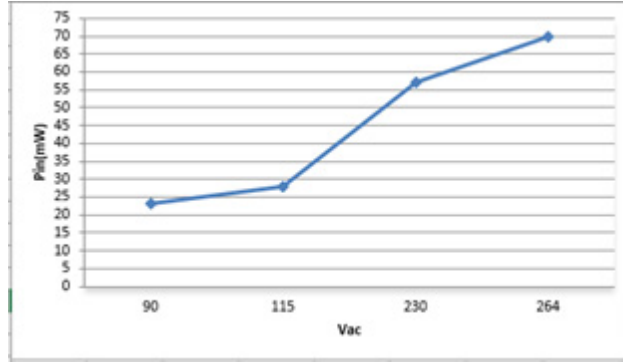

Figure 10.

COC V5 TIER2 SPECIFICATION AND AVERAGE/LIGHT LOAD EFFICIENCY

(Test condition: all efficiency is tested at board end)

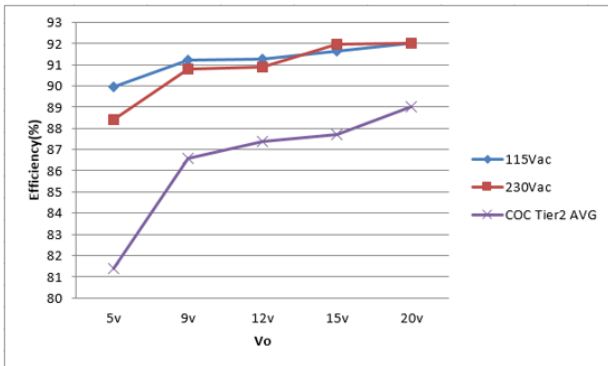

Figure 11. Avg Efficiency vs. COC V5 Tier2

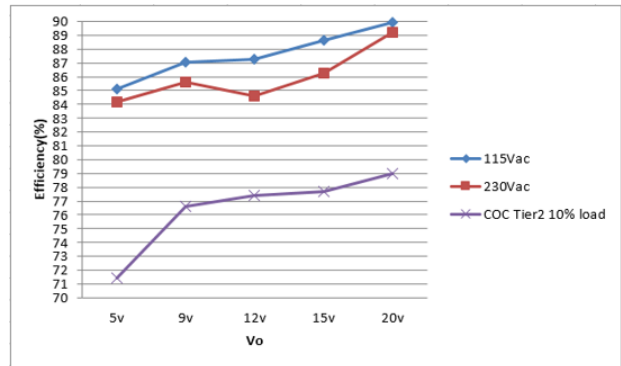

Figure 12. 10% Efficiency vs. COC V5 Tier2

EFFICIENCY VS. OUTPUT LOAD CURVES

(Test condition: all efficiency is tested at board end)

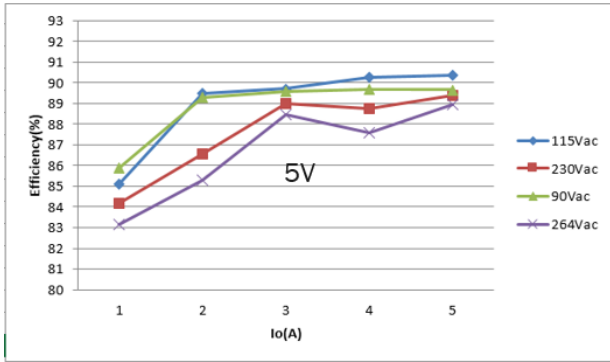

Figure 13. PD_5V Output

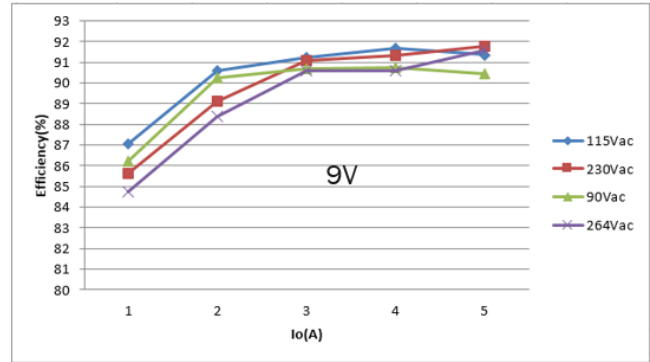

Figure 14. PD_9V Output

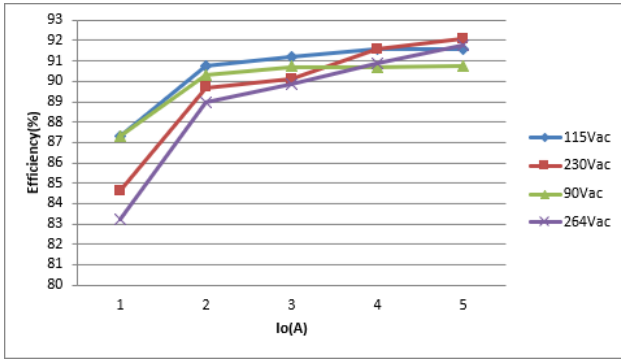

Figure 15. PD_12V Output

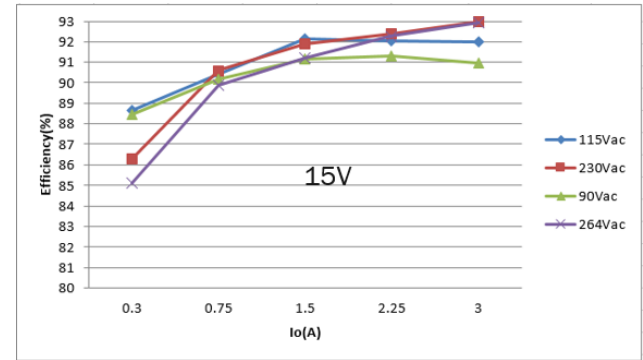

Figure 16. PD_15V Output

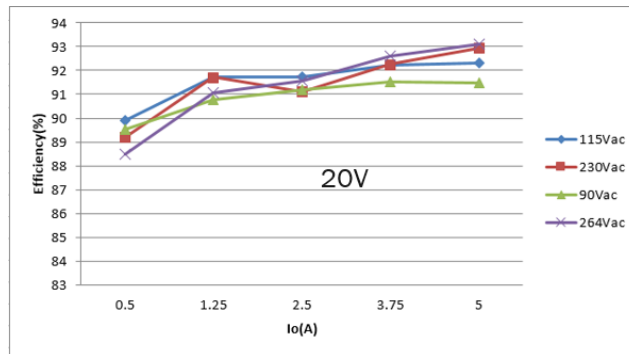

Figure 17. PD_20V Output

PFC VALLEY SWITCHING

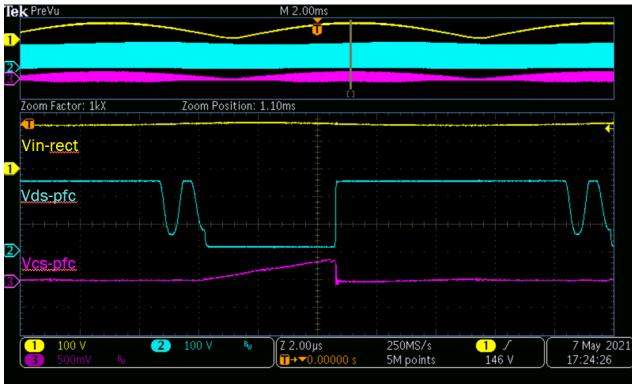

Figure 18. 115 Vac & 20 V 5 A
(CH1: Vin-rect, CH2: Vds-pfc, CH3: Vcs_pfc)

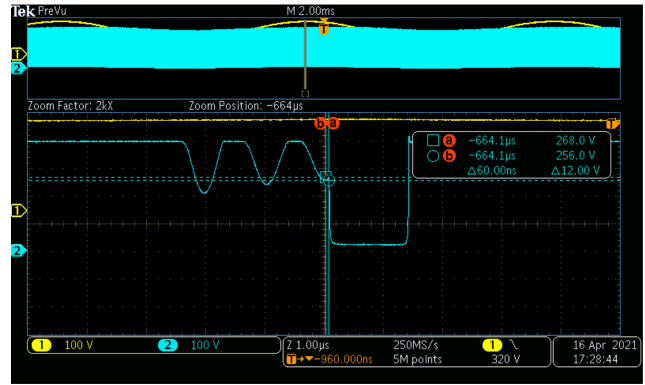

Figure 19. 230 Vac & 20 V 5 A
(CH1: Vin-rect, CH2: Vds-pfc)

INPUT CURRENT AT LL AND HL



Figure 20. 90 Vac & 20 V 5 A
(CH1: Vin-rect, CH3: lin)

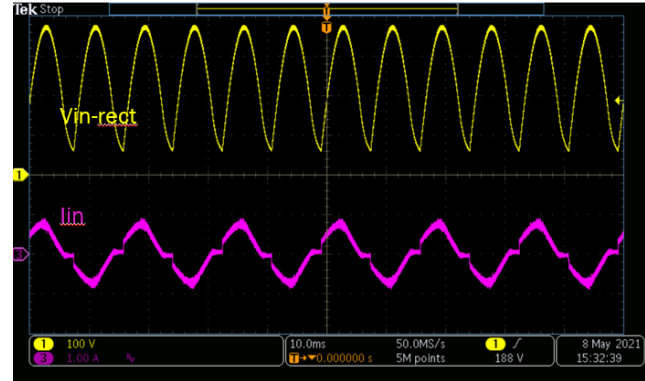

Figure 21. 64 Vac & 20 V 5 A
(CH1: Vin-rect, CH3: lin)

PFC OPERATION WAVEFORM AT LL AND HL

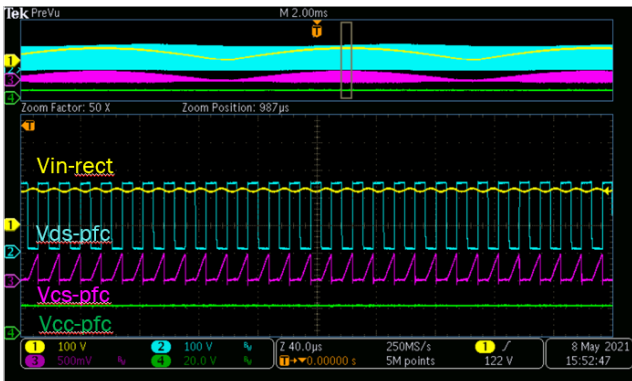

Figure 22. 90 Vac & 20 V 5 A
(CH1: Vin-rect, CH2: Vds-pfc, CH3: Vcs-pfc,
CH4: Vcc-pfc)

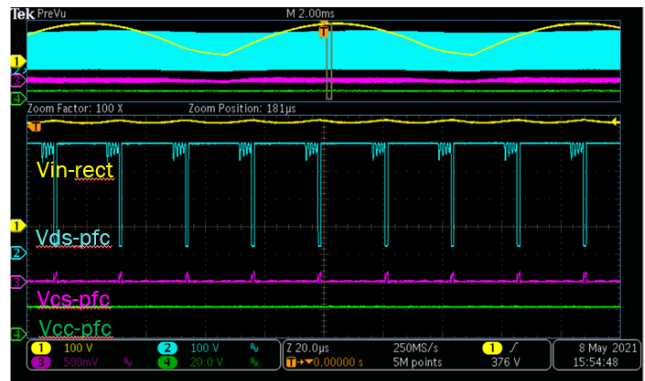

Figure 23. 264 Vac & 20 V 5 A
(CH1: Vin-rect, CH2: Vds-pfc, CH3: Vcs-pfc,
CH4: Vcc-pfc)

EVBUM2818/D

PFC LL TO HL AND HL TO LL CHANGE

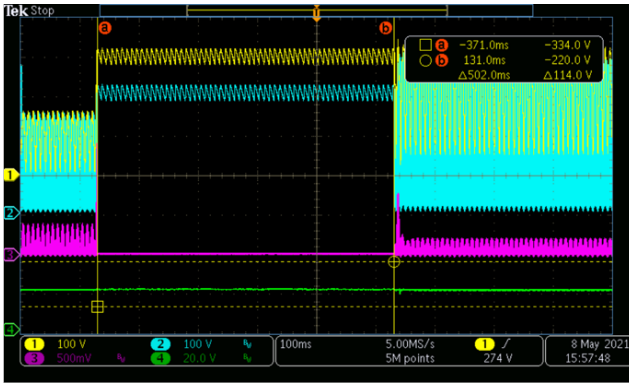

Figure 24. 115 Vac to 230 Vac at 20 V 5 A
(CH1: Vin-rect, CH2: Vds-pfc, CH3: Vcs-pfc,
CH4: Vcc-pfc)

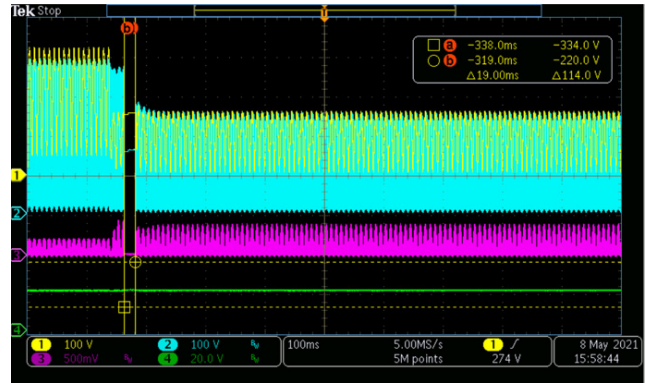

Figure 25. 230 Vac to 115 Vac at 20 V 5 A
(CH1: Vin-rect, CH2: Vds-pfc, CH3: Vcs-pfc,
CH4: Vcc-pfc)

PD VOLTAGE CHANGE

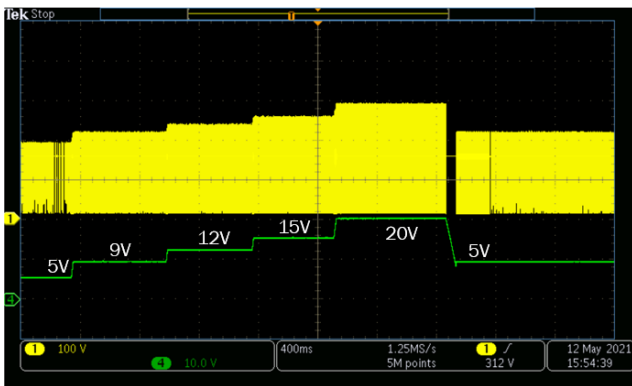

Figure 26. 115 Vac, No Load
(CH1: Vds, CH4: Vo)

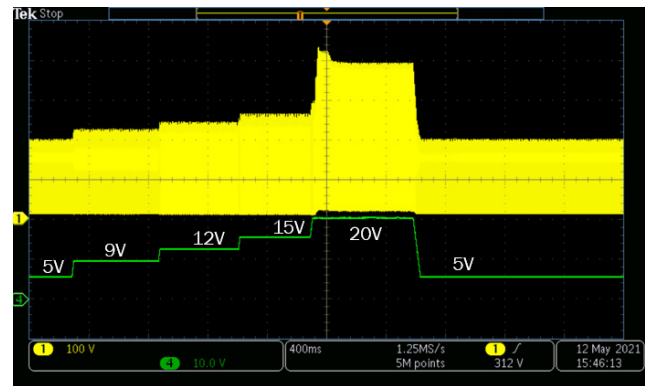

Figure 27. 115 Vac, 3 A Load
(CH1: Vds, CH4: Vo)

PRIMARY AND SEC. FET STRESS AT 264 Vac & 20 V 5 A

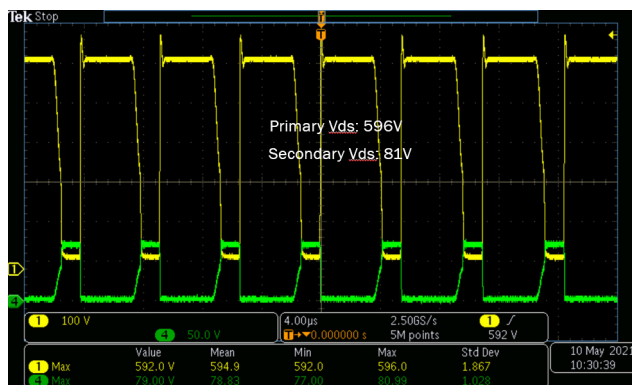

Figure 28. (CH1: Vds, CH4: Vds-sec)

SYN. DRIVE DURING LOAD TRANSITION AT 264 V

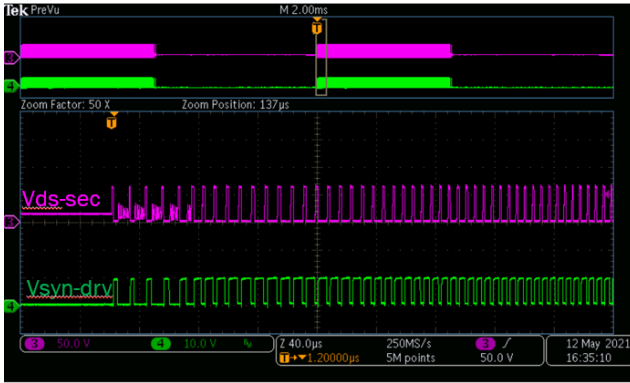

Figure 29. 264 Vac & 15 V, 0 to 3 A
(CH3: Vds-sec, CH4: Vsyn-drv)

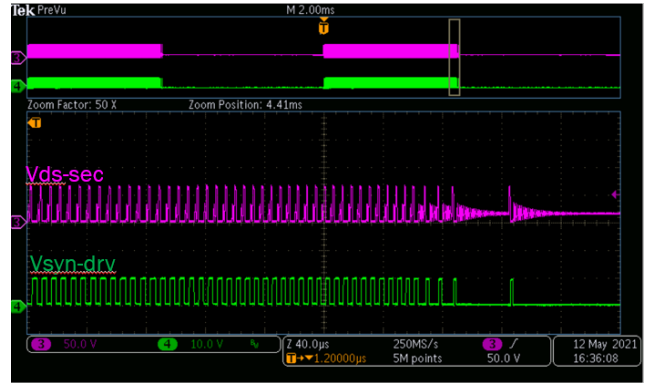

Figure 30. 264 Vac & 15 V, 3 A to 0
(CH3: Vds-sec, CH4: Vsyn-drv)

OUTPUT RIPPLE @ 90 Vac INPUT

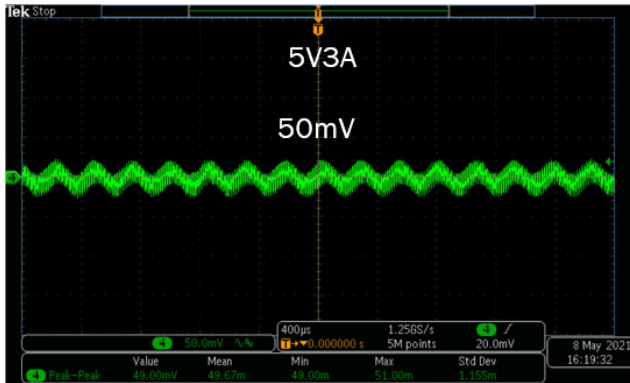

Figure 31. 5 V 3 A Output (CH4: Vo)

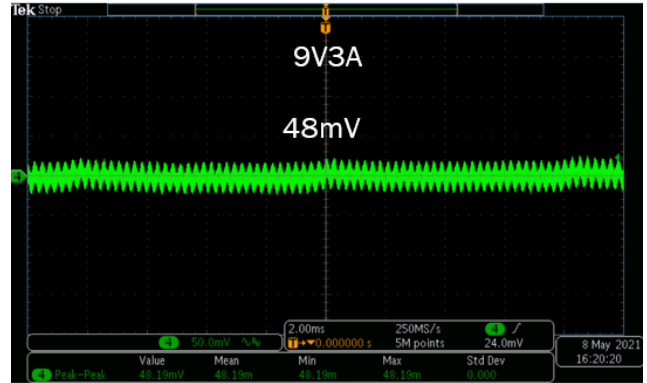

Figure 32. 9 V 3 A Output (CH4: Vo)

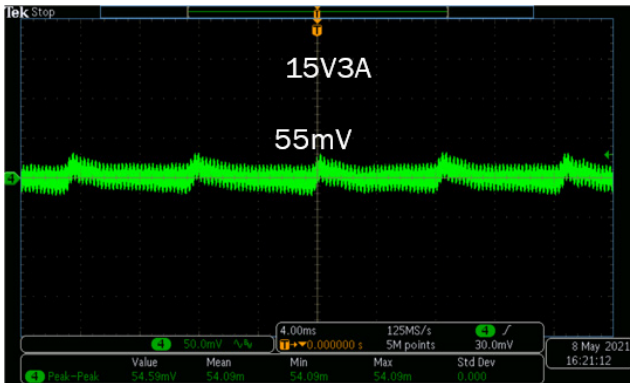

Figure 33. 15 V 3 A Output (CH4: Vo)

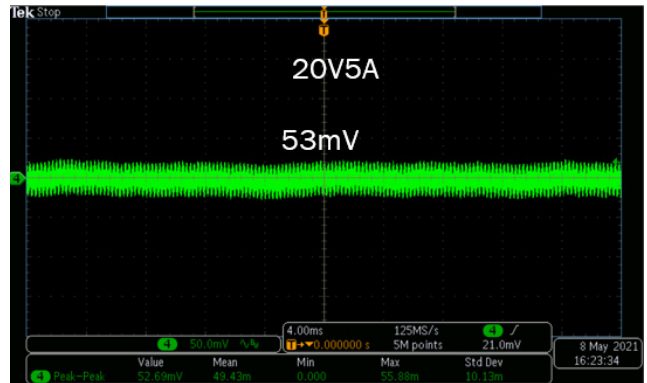

Figure 34. 20 V 5 A Output (CH4: Vo)

EVBUM2818/D

RIPPLE AT 90 Vac & 20 V 2.5 A (BEFORE PFC OPERATION)

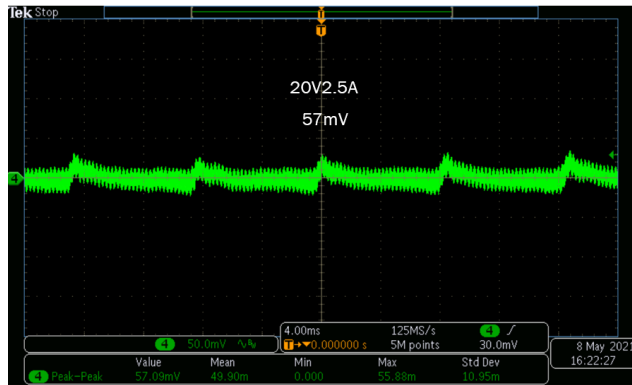

Figure 35. 20 V Output (CH4: Vo)

PWM OPERATION FREQUENCY AT FULL LOAD

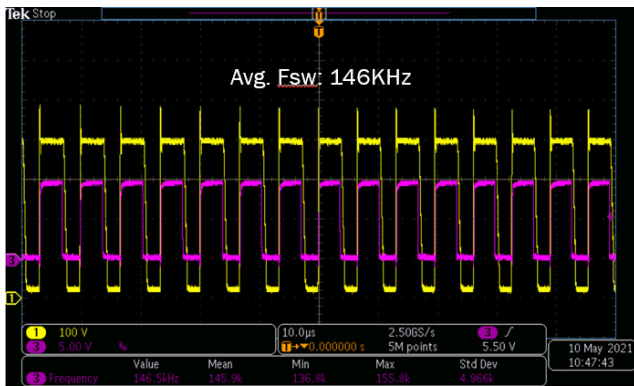

Figure 36. 90 Vac and 20 V 5 A
(CH1: Vds, CH3: Vsyn-driv)

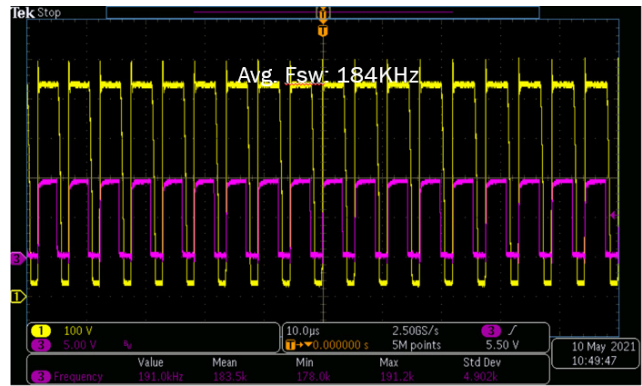

Figure 37. 264 Vac and 20 V 5 A
(CH1: Vds, CH3: Vsyn-driv)

NCP1343 TRANSITION LOAD FROM 0 – 5 A AT 90 Vac & 20 V

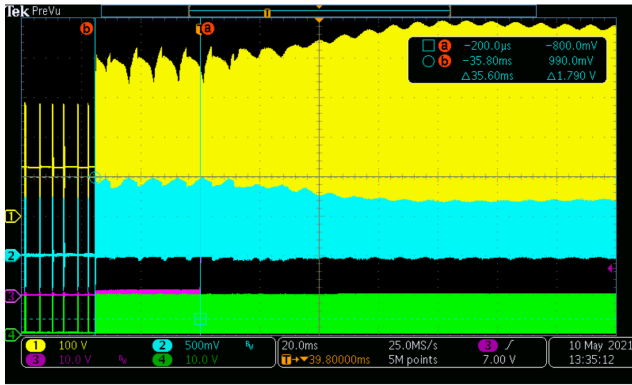

Figure 38. (CH1: Vds_pwm, CH: Vcs_pwm, CH3: Vcc_pfc, CH4: Vsyn_drv)

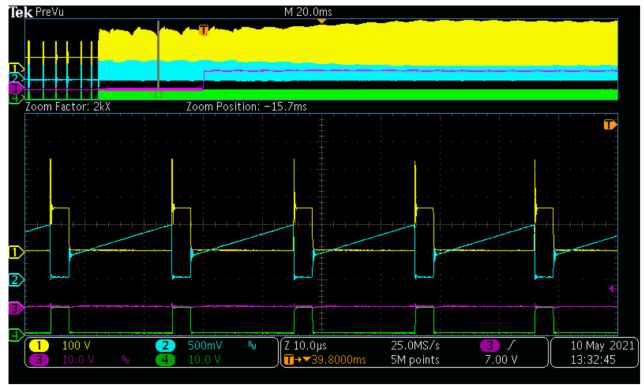

Figure 39. (CH1: Vds_pwm, CH: Vcs_pwm, CH3: Vcc_pfc, CH4: Vsyn_drv)

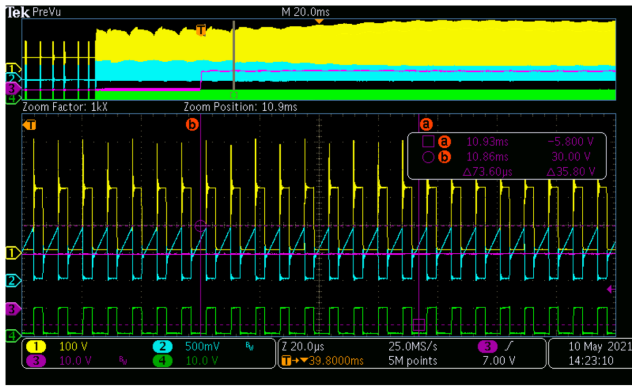

Figure 40.

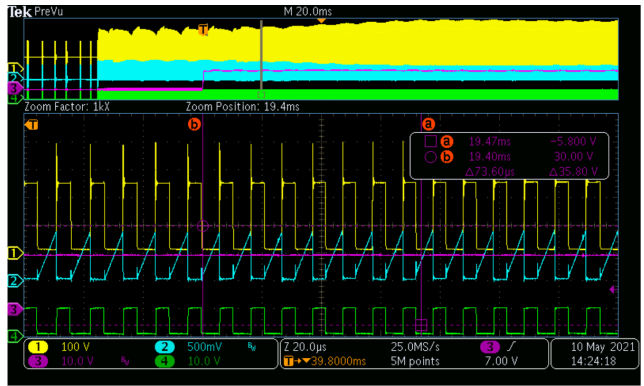

Figure 41.

PRI. & SEC. Vds AND SYNCHRONOUS DRIVE WAVEFORM

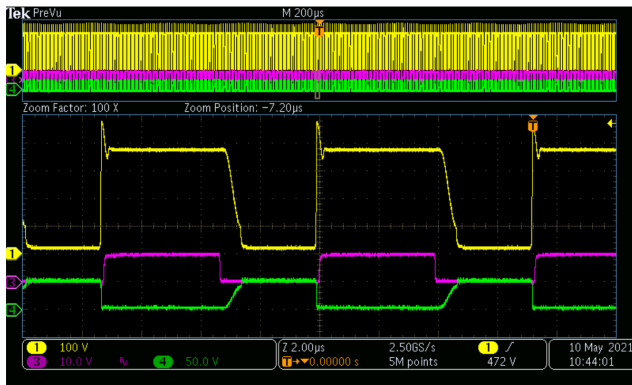

Figure 42. 90 Vac (CH1: Vds_sec, CH2: Vdrv)



Figure 43. 115 Vac (CH1: Vds_sec, CH2: Vdrv)

SHORT CIRCUIT PROTECTION AND T_{ovld} , Tauto-recovery TIME

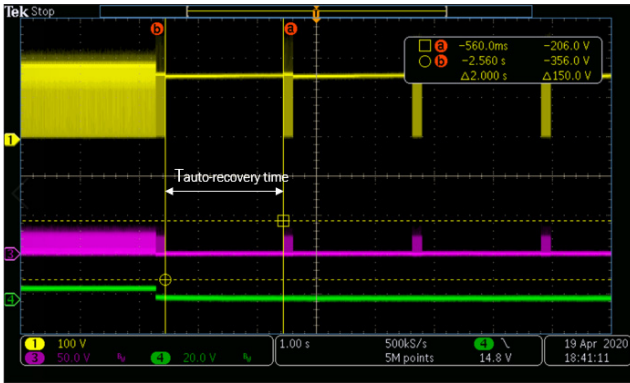

Figure 44. (CH1: Vds-pwm, CH3: Vsec-ds, CH4: Vo)

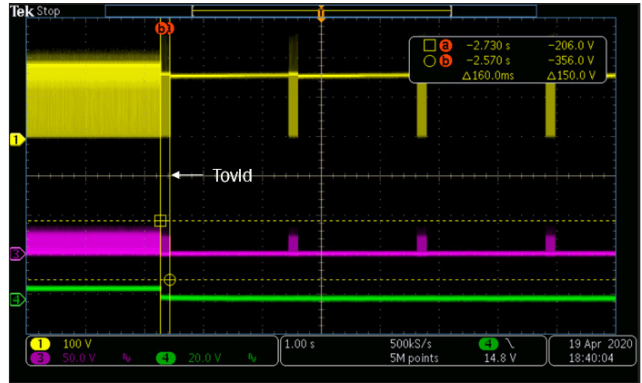

Figure 45. (CH1: Vds-pwm, CH3: Vsec-ds, CH4: Vo)

PRIMARY AND SEC. FET STRESS DURING SCP

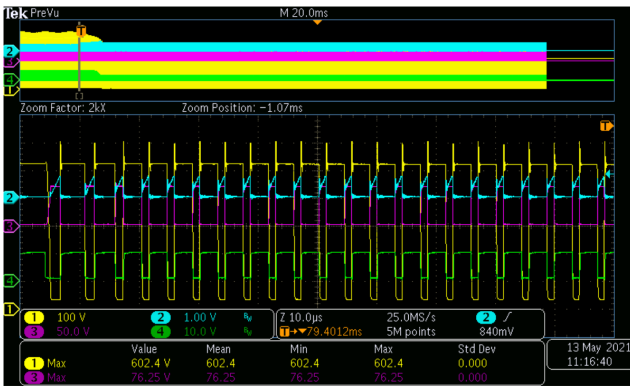

Figure 46. SCP at 264 Vac Input, 20 V 3.25 A Output
(CH1: Vds_pwm, CH2: Vcs_pwm, CH3: Vds_sec, CH4: Vsyn_drv)

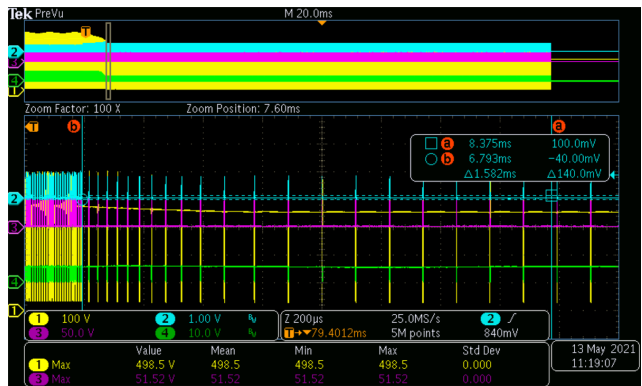

Figure 47. Startup at 264 Vac Input, 5 V 3 A Output
(CH1: Vds_pwm, CH2: Vcs_pwm, CH3: Vds_sec, CH4: Vsyn_drv)

OVP & X2 DISCHARGE TEST

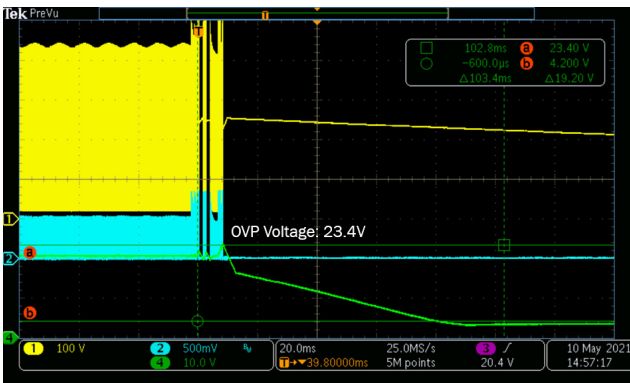

Figure 48. OVP (Open Loop) at 115 Vac Input, 20 V Output
(CH1:Vds_pwm, CH2:Vcs_pwm, CH4: Vo)

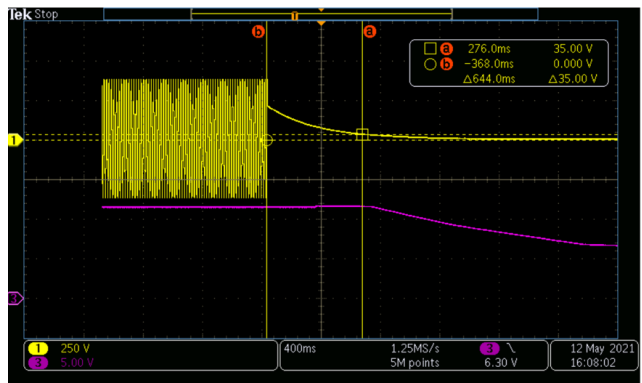

Figure 49. Plug Out AC at 264 Vac Input, 20 V & No Load
(CH1: Vac, CH3: Vcc1)

THERMAL IMAGE @ 20 V 3.25 A OUTPUT

Table 1.

Input	PFC Side	PWM Side
90 Vac	<p>FLUKE 88.8°C 自动 2 100.3 最大 99.1 最小 27.1 69.8 25.8 ε=0.95 BG=26.4 T=100% 3/31/16 10:31:18</p>	<p>FLUKE 83.3°C 自动 2 123.2 最大 122.8 最小 28.4 58.7 27.7 ε=0.95 BG=26.4 T=100% 3/31/16 10:34:05</p>
115 Vac	<p>FLUKE 87.8°C 自动 2 96.9 最大 96.1 最小 28 77.8 27.4 ε=0.95 BG=26.4 T=100% 3/31/16 10:54:56</p>	<p>FLUKE 87.7°C 自动 2 122.9 最大 123.2 最小 28.5 57.1 28.5 ε=0.95 BG=26.4 T=100% 3/31/16 10:55:15</p>
230 Vac	<p>FLUKE 80.8°C 自动 2 98.8 最大 98.3 最小 27.9 69.3 26.4 ε=0.95 BG=26.4 T=100% 3/31/16 11:56:44</p>	<p>FLUKE 83.0°C 自动 2 133.7 最大 133.0 最小 26.6 45.9 25.9 ε=0.95 BG=26.4 T=100% 3/31/16 11:57:06</p>
264 Vac	<p>FLUKE 81.3°C 自动 2 95.7 最大 95.4 最小 27.9 72.2 27.4 ε=0.95 BG=26.4 T=100% 3/31/16 12:29:27</p>	<p>FLUKE 93.6°C 自动 2 134.2 最大 133.0 最小 28.4 52.2 28.0 ε=0.95 BG=26.4 T=100% 3/31/16 12:29:42</p>

EVBUM2818/D

EMI

EMI Test at 230 Vac & Full Load

EMI TEST REPORT

Organization:	Operator:	EUT:
Place:	Time: 2021/5/11/17:32	Test equipment:KH3962
Detector: PK+AV	Test-time[ms]: 30	SN: 620883
Limit: EN55022B	Transductor(PK/AV): PK / AV	JZ: 2,15,665
Remark:		

Start(MHz)	End(MHz)	Step(MHz)
0.150	2.000	0.002
2.000	10.000	0.010
10.000	30.000	0.025

dBuV

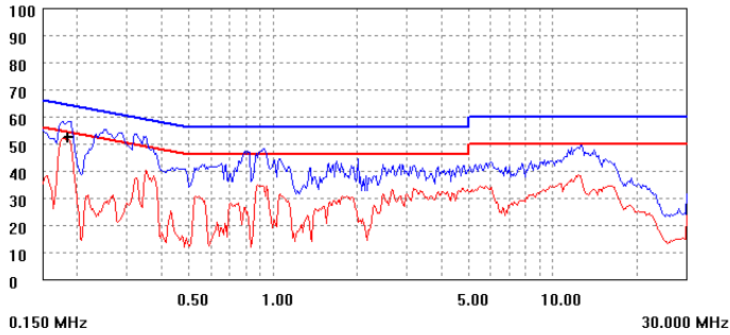

(AV)	freq(MHz)	lev(dBuV)	Lim(dBuV)	Δ(lev-Lim)
	0.185	52.3	54.3	-1.9

Figure 50. Line

EMI TEST REPORT

Organization:	Operator:	EUT:
Place:	Time: 2021/5/11/17:27	Test equipment:KH3962
Detector: PK+AV	Test-time[ms]: 30	SN: 620883
Limit: EN55022B	Transductor(PK/AV): PK / AV	JZ: 2,14,1438
Remark:		

Start(MHz)	End(MHz)	Step(MHz)
0.150	2.000	0.002
2.000	10.000	0.010
10.000	30.000	0.025

dBuV

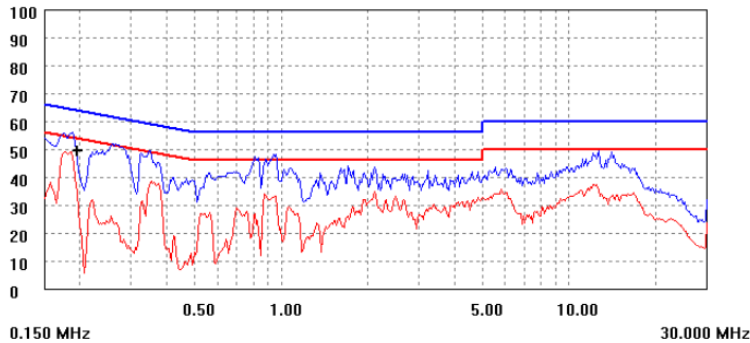

(AV)	freq(MHz)	lev(dBuV)	Lim(dBuV)	Δ(lev-Lim)
	0.195	49.5	53.8	-4.3

Figure 51. Neutral

EVBUM2818/D

EMI Test at 115 Vac & Full Load

EMI TEST REPORT

Organization:		Operator:	EUT:
Place:		Time: 2021/5/11/17:39	Test equipment:KH3962
Detector:	PK+AV	Test-time(ms): 30	SN: 620883
Limit:	EN55022B	Transductor(PK/AV): PK / AV	JZ: 2,15,666
Remark:			
Start(MHz)	End(MHz)	Step(MHz)	
0.150	2.000	0.002	
2.000	10.000	0.010	
10.000	30.000	0.025	

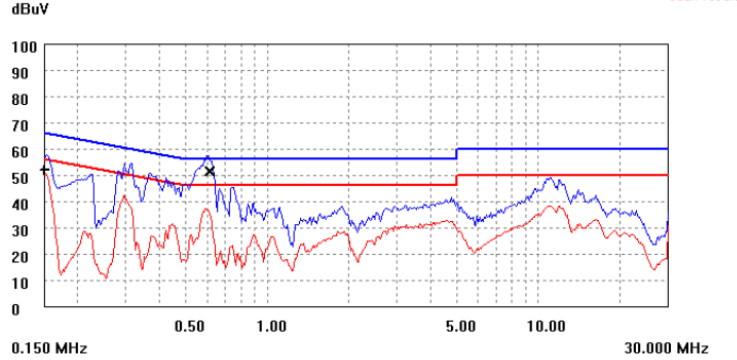

(QP)	freq(MHz)	lev(dBuV)	Lim(dBuV)	Δ(lev-Lim)
	0.611	51.5	56.0	-4.5
(AV)	freq(MHz)	lev(dBuV)	Lim(dBuV)	Δ(lev-Lim)
	0.150	52.1	56.0	-3.9

Figure 52. Line

EMI TEST REPORT

Organization:		Operator:	EUT:
Place:		Time: 2021/5/11/17:44	Test equipment:KH3962
Detector:	PK+AV	Test-time(ms): 30	SN: 620883
Limit:	EN55022B	Transductor(PK/AV): PK / AV	JZ: 2,15,664
Remark:			
Start(MHz)	End(MHz)	Step(MHz)	
0.150	2.000	0.002	
2.000	10.000	0.010	
10.000	30.000	0.025	

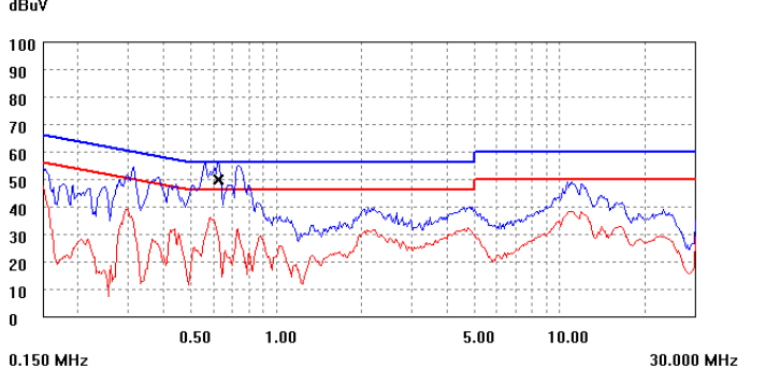

(QP)	freq(MHz)	lev(dBuV)	Lim(dBuV)	Δ(lev-Lim)
	0.623	49.7	56.0	-6.3

Figure 53. Neutral

EVBUM2818/D

BOM

Table 2. BOM

Item	Qty	Reference	Type	Part Name	MFR	Value	Package	Description
1	1	Q9	NMOSFET	BSS123LT1G	SOT23	onsemi	0.2 A, 100 V	NMOSFET
2	1	C45	Ceramic Capacitor	Std	603	std	0.1 μ F	Capacitor, Ceramic, 50 V, 10%
3	1	C44	Ceramic Capacitor	/885012206120	603	Würth	0.1 μ F, 100 V	Capacitor, Ceramic, 100 V, 10%
4	1	C37	Ceramic Capacitor	/885012206073	603	Würth	0.22 μ F	Capacitor, Ceramic, 25 V, 10%
5	2	C1, C5	Film Capacitor	ECWFD2W684Q	THT, 10 mm, 13 mm x 6 mm x 12 mm	Panasonic	0.68 μ F, 450 V	Film capacitor
6	2	C9, C33	Ceramic Capacitor	/885012206077	603	Würth	100 pF	Capacitor, Ceramic, 50 V, 10%
7	1	C8	Ceramic Capacitor	/885012206083	603	Würth	102	Capacitor, Ceramic, 50 V, 10%
8	3	C26, C31, C47	Ceramic Capacitor	C3216X7T2W104K	1206	TDK	104, 450 V	Capacitor, Ceramic, SMD, 5%
9	1	C52	Ceramic Capacitor	/885012106018	603	Würth	2.2 μ F, 16 V	Capacitor, Ceramic, 16 V, 10%
10	1	C12	Ceramic Capacitor	/885012006085	603	Würth	1 nF, 100 V	Capacitor, Ceramic, SMD, 5%
11	4	C39, C49-50, C70	Ceramic Capacitor	/885012206076	603	Würth	1 μ F, 25 V	Capacitor, Ceramic, 25 V, 10%
12	1	C27	Ceramic Capacitor	C2012X7R1E106K	805	TDK	10 μ F, 25 V	Capacitor, Ceramic, 25 V, 10%
13	1	C35	Ceramic Capacitor	/885012206085	603	Würth	2.2 μ F	Capacitor, Ceramic, 50 V, 10%
14	1	C36	Ceramic Capacitor	/885012106018	603	Würth	2.2 μ F	Capacitor, Ceramic, 16 V, 10%
15	1	C24	Ceramic Capacitor	/885012206079	603	Würth	220 pF	Capacitor, Ceramic, 50 V, 10%
16	1	C25	X2 Capacitor	/890324024002	THT, 12.5 mm, 15 mm x 7 mm x 12 mm	Würth	224, X2	X2 capacitor, Safety standard approved, 10%
17	1	C34	Ceramic Capacitor	/885012006053	603	Würth	22 pF	Capacitor, Ceramic, 50 V, 10%
18	1	C41	Ceramic Capacitor	/885012206091	603	Würth	22 nF	Capacitor, Ceramic, 50 V, 10%
19	2	C38, C69	Ceramic Capacitor	/885012206083	603	Würth	330 pF	Capacitor, Ceramic, 50 V, 10%
20	1	C6	Ceramic Capacitor	Std	603	Std	36 pF	Capacitor, Ceramic, 50 V, 10%
21	1	C40	Ceramic Capacitor	/885012206092	603	Würth	33nF	Capacitor, Ceramic, 50 V, 10%
22	4	C2, C4, C29, C43	Ceramic Capacitor	C1608X5R1E475K080AC	603	TDK	4.7 μ F, 25 V	Capacitor, Ceramic, 25 V, 10%
23	1	C3	Ceramic Capacitor	C3216C0G2J471J	1206	TDK	470 pF, 630 V	Capacitor, Ceramic, Chip, 5%
24	1	C10	Ceramic Capacitor	CD45-B2GA471K-NKA	Lead type	TDK	470 pF, Y1	HV Ceramic Capacitor, safety standard approved, 10%
25	1	C68	Ceramic Capacitor	std	603	Würth	nc	Capacitor, Ceramic, 50 V, 10%
26	1	C20	Ceramic Capacitor	C2012X7S2A105K	805	TDK	nc	Capacitor, Ceramic, 100 V, 10%
27	1	C42	Ceramic Capacitor	Std	603	Würth	nc	Capacitor, Ceramic, 50 V, 10%
28	2	D2, D4	Bridge rectifier	Z4GP40MH	Z4PAK	ZOWIE	4 A, 1000 V	Bridge Rectifier, 1000 V, 4 A
29	1	D9	Rectifier	S3J	SMC	onsemi	3 A, 600 V	General Rectifier
30	1	DNR	Varistor	820573011	TH	Würth	10D471K	Varistor, 10D471K
31	1	D22	Switching diode	BAS21HT1G	SOD323	onsemi	0.2 A, 250 V	Switching diode, SMD
32	1	D7	Switching diode	BAS21HT1G	SOD323	onsemi	0.2 A, 250 V	Switching diode, SMD
33	2	D16, D24	Switching diode	BAT54HT1G	SOD323	onsemi	0.2 A, 30 V	Switching diode, SMD
34	1	D20	Switching diode	NSD350HT1G	SOD323	onsemi	0.2 A, 350 V	Switching diode, SMD
35	1	D5	General rectifier	4007	SOD123FL	std	0.8 A, 600 V	General Rectifier, 0.8 A, 600 V
36	2	D12-13	General rectifier	4007	SOD123FL	std	0.8 A, 600 V	General Rectifier, 0.8 A, 600 V
37	4	D8, D17-18, D23	Switching diode	BAS21HT1G	SOD323	onsemi	0.2 A, 250 V	Switching diode, SMD
38	1	FB2	Ferrite bead	742792511	1812	Würth	120 Ω @ 100 M, 3 A	120 Ω @ 100 MHz
39	1	FB1	Ferrite bead	PZ3225D601-3R0TFONL	1210	Shunlord	600 Ω @ 100 M, 3 A	600 Ω @ 100 MHz
40	1	L1	Common filter	Custom	TH type	Customed	30 μ H	T type, 8*4*3 NiZn core
41	1	L2	Common filter	Custom	TH type	Customed	18 mH	CM Filter, T14*8*7 MnZn core
42	1	F1	Fuse	20T-016H	Axial lead	Hollyfuse	3.15 A, 250 Vac	Micro Fuse, 1.6 A/250 V

EVBUM2818/D

Table 2. BOM (continued)

Item	Qty	Reference	Type	Part Name	MFR	Value	Package	Description
43	1	Q7	NPN Transistor	MMBT3904LT1G	SOT23	onsemi		General NPN Transistor, SMD
44	1	Q13	PNP Transistor	MMBT3906LT1G	SOT23	onsemi		General PNP Transistor, SMD
45	1	D3	Ultrafast Rectifier	MURD550PFG	DPAK	onsemi	5 A, 520 V	Ultrafast Rectifier, 5 A, 520 V
46	1	U5	PFC controller	NCP1623ASNT1G	TSOP6	onsemi		2 stage Follower/Boost PFC controller
47	1	U3	Syn. rectified controller	NCP4307FASNT1G	TSOP6	onsemi		Syn. Controller
48	1	U1	PWM controller	NCP1343AMDCBBD1R2G	SO9	onsemi		2x PEM CCM/QR controller
49	1	NTC1	NTC	SDNT1608X104J4250HTF	603	Shunlord	100 k	NTC, 0603, replaced by 100 kΩ resistor
50	1	NTC2-3	NTC	SDNT1608X104J4250HTF	603	Shunlord	nc	NTC, 0603, no connect
51	2	U4, U11	Optical coupler	FODM1009	LSOP4	onsemi		optical coupler, standard SOP package
52	1	L3	Toroidal Line Choke	7447021	TH type	Würth	100 μH	Toroidal Line Choke, 15.8 x 8.5, 2.5 A
53	1	L6	SMD Inductor	MCL1608S4R7MT	603	Shunlord	4.7 μH	
54	1	R11	Resistor	Std	603	Std	0 Ω	Resistor, Chip, 1/10 W, 1%
55	2	R48, R57	Resistor	Std	603	Std	0 Ω	Resistor, Chip, 1/10 W, 1%
56	1	R61	Resistor	Std	603	Std	1 Ω	Resistor, Chip, 1/10 W, 1%
57	3	R13, R32, R49	Resistor	Std	603	Std	100 kΩ	Resistor, Chip, 1/10 W, 1%
58	1	R21	Resistor	Std	603	Std	10 kΩ	Resistor, Chip, 1/10 W, 1%
59	4	R23, R38, R46, R66	Resistor	Std	603	Std	10 Ω	Resistor, Chip, 1/10 W, 1%
60	3	R3, R34, R36	Resistor	Std	603	Std	1 kΩ	Resistor, Chip, 1/10 W, 1%
61	1	R8	Resistor	Std	603	Std	2.4 kΩ	Resistor, Chip, 1/10 W, 1%
62	1	R60	Resistor	Std	603	Std	200 Ω	Resistor, Chip, 1/10 W, 1%
63	1	R33	Resistor	Std	603	Std	200 kΩ	Resistor, Chip, 1/10 W, 1%
64	1	R65	Resistor	Std	805	Std	30 Ω	Resistor, Chip, 1/8 W, 1%
65	3	R39, R52, R56	Resistor	Std	603	Std	22 kΩ	Resistor, Chip, 1/10 W, 1%
66	1	R9	Resistor	Std	603	Std	2 kΩ	Resistor, Chip, 1/10 W, 1%
67	2	R27, R53	Resistor	Std	603	Std	270 kΩ	Resistor, Chip, 1/10 W, 1%
68	1	R43	Resistor	Std	603	Std	30 kΩ	Resistor, Chip, 1/10 W, 1%
69	1	R63	Resistor	Std	603	Std	300 kΩ	Resistor, Chip, 1/10 W, 1%
70	1	R16	Resistor	Std	603	Std	36 kΩ	Resistor, Chip, 1/10 W, 1%
71	1	R20	Resistor	Std	603	Std	390 kΩ	Resistor, Chip, 1/10 W, 1%
72	2	R26, R28	Resistor	Std	603	Std	4.7 Ω	Resistor, Chip, 1/10 W, 1%
73	1	R30	Resistor	Std	603	Std	5.1 kΩ	Resistor, Chip, 1/10 W, 1%
74	2	R47, R54	Resistor	Std	603	Std	47 Ω	Resistor, Chip, 1/10 W, 1%
75	1	R28	Resistor	Std	603	Std	47 kΩ	Resistor, Chip, 1/10 W, 1%
76	1	R22	Resistor	Std	603	Std	510 Ω	Resistor, Chip, 1/10 W, 1%
77	1	R29	Resistor	Std	603	Std	nc	Resistor, Chip, 1/10 W, 1%,
78	2	R50-51	Resistor	ERJ8BQFR24V	1206	Panasonic	0,24 Ω	Resistor, Chip, 1/2 W, 1%
79	2	R4-5	Resistor	ERJ8BQFR56V	1206	Panasonic	0,56 Ω	Resistor, Chip, 1/2 W, 1%
80	1	R40	Resistor	std	1206	Std	1.6 MΩ	Resistor, Chip, 1/4 W, 1%
81	2	R1-2	Resistor	Std	1206	Std	120 Ω	Resistor, Chip, 1/4 W, 1%
82	2	R7, R58	Resistor	Std	1206	Std	2.4 MΩ	Resistor, Chip, 1/4 W, 1%
83	2	R31, R35	Resistor	Std	1206	Std	2.7 kΩ	Resistor, Chip, 1/4 W, 1%
84	1	R12	Resistor	Std	1206	Std	22 Ω	Resistor, Chip, 1/4 W, 1%
85	2	R41-42	Resistor	Std	1206	Std	2 MΩ	Resistor, Chip, 1/4 W, 1%
86	1	R45	Resistor	Std	1206	Std	390 kΩ	Resistor, Chip, 1/4 W, 1%

EVBUM2818/D

Table 2. BOM (continued)

Item	Qty	Reference	Type	Part Name	MFR	Value	Package	Description
87	1	R25	Resistor	ERJ8BQFR005V	1206	Panasonic	5 mΩ	Resistor, Chip, 1/2 W, 1%
88	1	T2	Transformer	Customed	TH type	Custom	see specification	RM8, Ferroxcube 3C95, 6 Pin Bobbin
89	1	T1	PFC Inductor	Customed	TH type	Custom	200 μH	RM8, Ferroxcube 3C95 core, 6 Pin Bobbin
90	1	C46	Electrolytic capacitor	KF Series	6.3 mm x 11 mm	CapXon	22 μF, 100 V	size: 6.3 mm x 11 mm
91	3	C13-14, C48	Electrolytic solid capacitor	PS681M025F080P	8 mm x 14 mm	CapXon	680 μF, 25 V	size: 8 mm x 14 mm
92	1	C32	Electrolytic electrolytic capacitor	KL680M450J300A00H	18 mm x 30 mm	CapXon	68 μF, 450 V	size: 18 mm x 30 mm
93	1	Q1	MOSFET	FDMS86180	SO8FL	onsemi		MOSFET, NChan, 100 V
94	1	Q3	MOSFET	FCMT250N65S3	Power88	onsemi		MOSFET, NChan, 650 V
95	1	Q2	MOSFET	FCMT199N60	Power88	onsemi		MOSFET, NChan, 600 V
96	1	Q8	MOSFET	NTTFS4C02NT1G	u8FL	onsemi		MOSFET, NChan, 3.4 mΩ
97	1	J1	USB Type C connector	CUS31738616001	SMD	CSCONN		Type C connector, SMT
98	1	U10	PD Controller	FUSB15101	DFN4X4	onsemi		PD protocol controller
99	1	ZD2	Zener	MM3Z13VT1G	SOD323	onsemi	13 V	GENERIC ZENER-DIODE
100	1	ZD1	Zener	MM3Z18VT1G	SOD323	onsemi	18 V	GENERIC ZENER-DIODE
101	4	ESD1-4	ESD	SD05T1G	SOD323	onsemi	5 V	ESD protection device

REFERENCES

onsemi datasheet for NCP1623, NCP1343, NCP4307, FUSB15101, FCMT199N60, FCMT250N65, FDMS86180, NTTFS4C02

onsemi Design Notes DN05043

onsemi, **Onsemi**, and other names, marks, and brands are registered and/or common law trademarks of Semiconductor Components Industries, LLC dba "**onsemi**" or its affiliates and/or subsidiaries in the United States and/or other countries. **onsemi** owns the rights to a number of patents, trademarks, copyrights, trade secrets, and other intellectual property. A listing of **onsemi**'s product/patent coverage may be accessed at www.onsemi.com/site/pdf/Patent-Marking.pdf. **onsemi** is an Equal Opportunity/Affirmative Action Employer. This literature is subject to all applicable copyright laws and is not for resale in any manner.

The evaluation board/kit (research and development board/kit) (hereinafter the "board") is not a finished product and is not available for sale to consumers. The board is only intended for research, development, demonstration and evaluation purposes and will only be used in laboratory/development areas by persons with an engineering/technical training and familiar with the risks associated with handling electrical/mechanical components, systems and subsystems. This person assumes full responsibility/liability for proper and safe handling. Any other use, resale or redistribution for any other purpose is strictly prohibited.

THE BOARD IS PROVIDED BY ONSEMI TO YOU "AS IS" AND WITHOUT ANY REPRESENTATIONS OR WARRANTIES WHATSOEVER. WITHOUT LIMITING THE FOREGOING, ONSEMI (AND ITS LICENSORS/SUPPLIERS) HEREBY DISCLAIMS ANY AND ALL REPRESENTATIONS AND WARRANTIES IN RELATION TO THE BOARD, ANY MODIFICATIONS, OR THIS AGREEMENT, WHETHER EXPRESS, IMPLIED, STATUTORY OR OTHERWISE, INCLUDING WITHOUT LIMITATION ANY AND ALL REPRESENTATIONS AND WARRANTIES OF MERCHANTABILITY, FITNESS FOR A PARTICULAR PURPOSE, TITLE, NON-INFRINGEMENT, AND THOSE ARISING FROM A COURSE OF DEALING, TRADE USAGE, TRADE CUSTOM OR TRADE PRACTICE.

onsemi reserves the right to make changes without further notice to any board.

You are responsible for determining whether the board will be suitable for your intended use or application or will achieve your intended results. Prior to using or distributing any systems that have been evaluated, designed or tested using the board, you agree to test and validate your design to confirm the functionality for your application. Any technical, applications or design information or advice, quality characterization, reliability data or other services provided by **onsemi** shall not constitute any representation or warranty by **onsemi**, and no additional obligations or liabilities shall arise from **onsemi** having provided such information or services.

onsemi products including the boards are not designed, intended, or authorized for use in life support systems, or any FDA Class 3 medical devices or medical devices with a similar or equivalent classification in a foreign jurisdiction, or any devices intended for implantation in the human body. You agree to indemnify, defend and hold harmless **onsemi**, its directors, officers, employees, representatives, agents, subsidiaries, affiliates, distributors, and assigns, against any and all liabilities, losses, costs, damages, judgments, and expenses, arising out of any claim, demand, investigation, lawsuit, regulatory action or cause of action arising out of or associated with any unauthorized use, even if such claim alleges that **onsemi** was negligent regarding the design or manufacture of any products and/or the board.

This evaluation board/kit does not fall within the scope of the European Union directives regarding electromagnetic compatibility, restricted substances (RoHS), recycling (WEEE), FCC, CE or UL, and may not meet the technical requirements of these or other related directives.

FCC WARNING – This evaluation board/kit is intended for use for engineering development, demonstration, or evaluation purposes only and is not considered by **onsemi** to be a finished end product fit for general consumer use. It may generate, use, or radiate radio frequency energy and has not been tested for compliance with the limits of computing devices pursuant to part 15 of FCC rules, which are designed to provide reasonable protection against radio frequency interference. Operation of this equipment may cause interference with radio communications, in which case the user shall be responsible, at its expense, to take whatever measures may be required to correct this interference.

onsemi does not convey any license under its patent rights nor the rights of others.

LIMITATIONS OF LIABILITY: **onsemi** shall not be liable for any special, consequential, incidental, indirect or punitive damages, including, but not limited to the costs of requalification, delay, loss of profits or goodwill, arising out of or in connection with the board, even if **onsemi** is advised of the possibility of such damages. In no event shall **onsemi**'s aggregate liability from any obligation arising out of or in connection with the board, under any theory of liability, exceed the purchase price paid for the board, if any.

The board is provided to you subject to the license and other terms per **onsemi**'s standard terms and conditions of sale. For more information and documentation, please visit www.onsemi.com.

ADDITIONAL INFORMATION

TECHNICAL PUBLICATIONS:

Technical Library: www.onsemi.com/design/resources/technical-documentation
onsemi Website: www.onsemi.com

ONLINE SUPPORT: www.onsemi.com/support

For additional information, please contact your local Sales Representative at www.onsemi.com/support/sales